

DLSw+ SSP Setup Messages and Flow

Layer-2/3 protocol

(Switch-to-switch protocol, maintained between two DLSw nodes or routers - using non-canonical address formats)

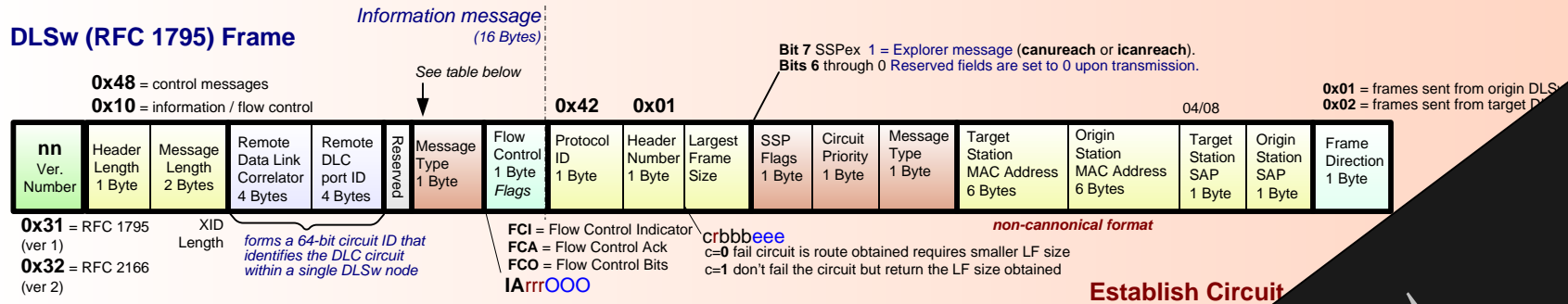

Each SDLC PU is presented to the DLSw Switch-to-Switch Protocol (SSP) as a unique Media Access Control (MAC)/service access point (SAP) address pair. With Local Token Ring-attached systems, a DLSw node appears as a source-route bridge. Remote Token Ring systems accessed via a DLSw node are seen as attached to an adjacent ring. This apparent adjacent ring is known as a virtual ring created within each DLSw node.

The overall DLSw operational process can be broken into three basic components: capabilities exchange, circuit establishment, and flow control.

In the context of DLSw, capabilities exchange involves the trading of information about capabilities associated with a DLSw session. This exchange of information is negotiated when the session is initiated and during the course of session operations. Circuit establishment in DLSw occurs between end systems. It includes the target end system and setting up data-link control connections between each end system and its DLSw flow control enables the establishment of independent, unidirectional flow control between

Establish Circuit

CANUREACH_Cs(D...
Can U Reach Station-
Type 0x03
ICANREACH...
I Can Reach Station-
Type 0x04

Message Types

Command	Description	Type
CANUREACH_ex	Can U Reach Station-explorer	0x03
CANUREACH_cs	Can U Reach Station-circuit start	0x03
ICANREACH_ex	I Can Reach Station-explorer	0x04
ICANREACH_cs	I Can Reach Station-circuit start	0x04
REACH_ACK	Reach Acknowledgment	0x05
DGRMFRAME	Datagram Frame	0x06
XIDFRAME	XID Frame	0x07
CONTACT	Contact Remote Station	0x08
CONTACTED	Remote Station Contacted	0x09
RESTART_DL	Restart Data Link	0x10
DL_RESTARTED	Data Link Restarted	0x11
ENTER_BUSY	Enter Busy	0x0C
EXIT_BUSY	Exit Busy	0x0D
INFOFRAME	Information (I) Frame	0x0A
HALT_DL	Halt Data Link	0x0E
DL_HALTED	Data Link Halted	0x0F
NETBIOS_NQ_ex	NETBIOS Name Query-explorer	0x0B
NETBIOS_NQ_cs	NETBIOS Name Query-circuit set	0x0B
NETBIOS_NR_ex	NETBIOS Name Recognized-explorer	0x0C
NETBIOS_NR_cs	NETBIOS Name Recognized-circuit set	0x0C
DATAFRAME	Data Frame	0x00
HALT_DL_NOACK	Halt Data Link with no ack	0x0F
NETBIOS_ANQ	NETBIOS Add Name Query	0x0B
NETBIOS_ANR	NETBIOS Add Name Recognized	0x0C
KEEPALIVE	Transport Keepalive	0x00
CAP_EXCHANGE	Capabilities Exchange	0x00
IFCM	Independent Flow Control Message	0x00
TEST_CIRCUIT_REQ	Test Circuit Request	0x00
TEST_CIRCUIT_RSP	Test Circuit Response	0x00

DLSw+ can connect to

- 1 - Token Ring to QLLC
- 2 - Token Ring to LLC2
- 3 - Token Ring to LLC2 (Frame Relay)
- 4 - Token Ring to LLC2 (Frame Relay)
- 5 - Token Ring to QLLC
- 6 - Ethernet to QLLC