

Four major functions:

- 1 - Learning MAC Addresses
(Storing MAC Address w interface)
- 2 - Forwarding frame to interface
(Based on MAC database)
- 3 - Filtering unneeded traffic
(Unless MAC address not in table)
- 4 - Loop detection and avoidance - STP

Transparent Bridges (802.1d)

(Using state changes with the Spanning Tree Algorithm)

Timers

Hello Time: Elapse time between generation of configuration messages by a bridge that assumes itself root.
Recommend time is 2 secs. (1-10).
Max Age: Discard time for stored configuration messages.
Recommend time is 20 secs. (6-200). - set at 100.
Forward Delay: Temporarily prevents a bridge from forwarding data packets to and from a link until a topology change has spread to all parts of a bridge domain.
Recommended time is 15 secs. (15-30).

BPDUs - Bridge Protocol Data Unit

The numerically **lowest** root ID, then lowest cost, then lowest transmitting bridge ID is determined the "Best" root bridge.

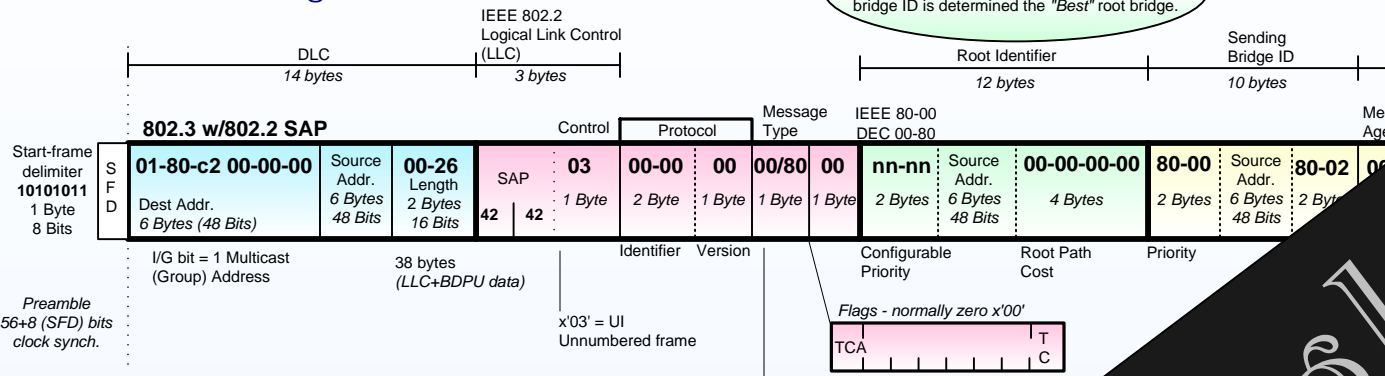

Cisco Defaults

Priorities:

(Used to select the Root Bridge)
 IEEE 32768 x'8000' (0-65535)
 DEC 128 x'0080' (0-255)

Interface Costs:

(Used to select the Designed port)
 10Mbps = 100
 100Mbps = 19
 1Gbps = 4
 10Gbps = 2

Troubleshooting:

show spanning
 debug spanning events
 show bridge group

Enable **PORTFAST** if spanning tree is disabled and no hub/switch device - else station must wait 20s+15s = 35s before forwarding frames on a switch.

set spantree portfast <mod/port> en

Spanning tree algorithm - Bridges transmit BPDUs messages to each other to calculate a spanning tree. These messages contain information to elect a single bridge and calculate the distance of the shortest path to the root bridge.

802.1d compliant transparent learning bridge builds a table of which Ethernet interfaces are connected to each other. For each particular Ethernet interface (computer) is on the network, the bridge forwards packets appropriately.

The transparent learning bridge will forward all traffic, including IPX, Apple Talk, IP, LAN Manager, and NetBIOS, **unconditionally**.

Transparent bridges refer to the design of the ports in the network.

Copyright © IT charts.com